

Capítulo 4. Entrenamiento Habilidades

Espaciales. Nivel Intermedio

EJERCICIOS. Obtención de vistas

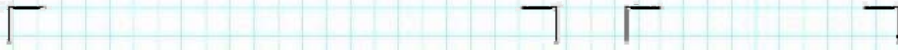

1

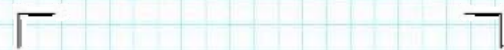

2

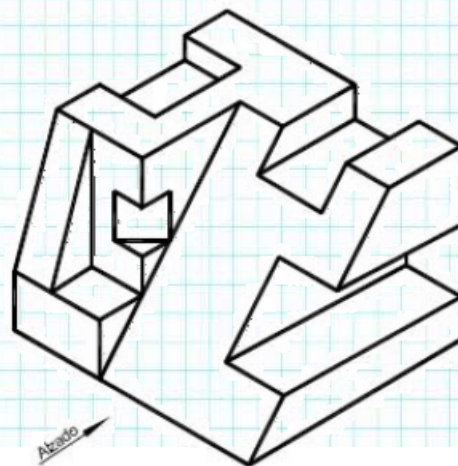
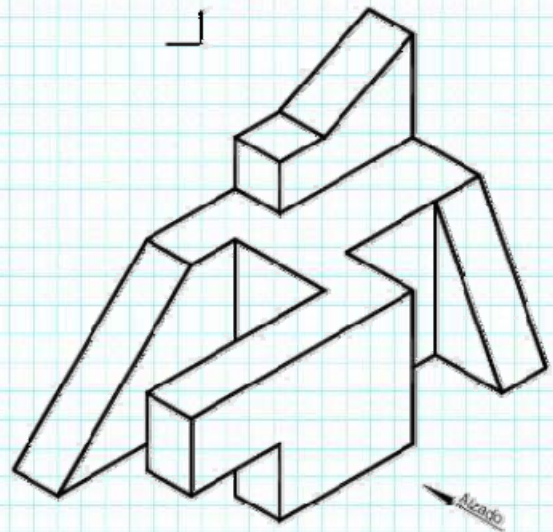
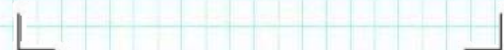

I
N
T
E
R
M
E
D
I
O

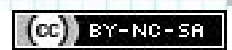

3

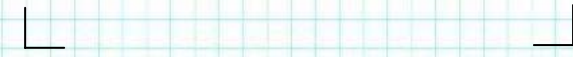
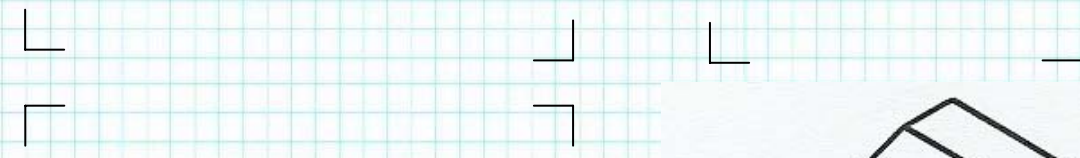
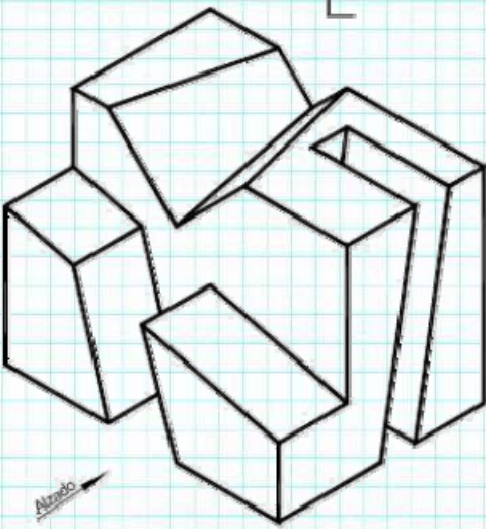

4

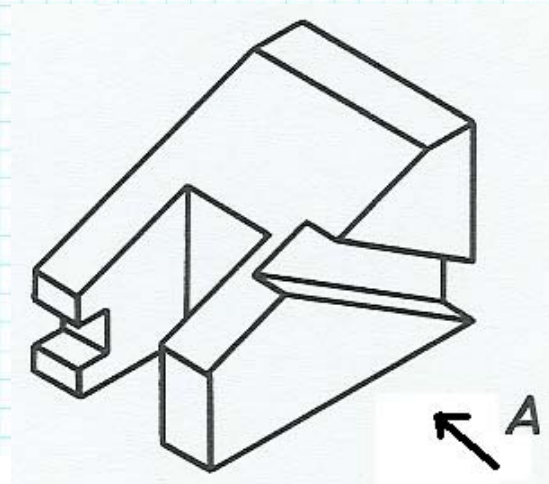

I
N
T
E
R
M
E
D
I
O

5

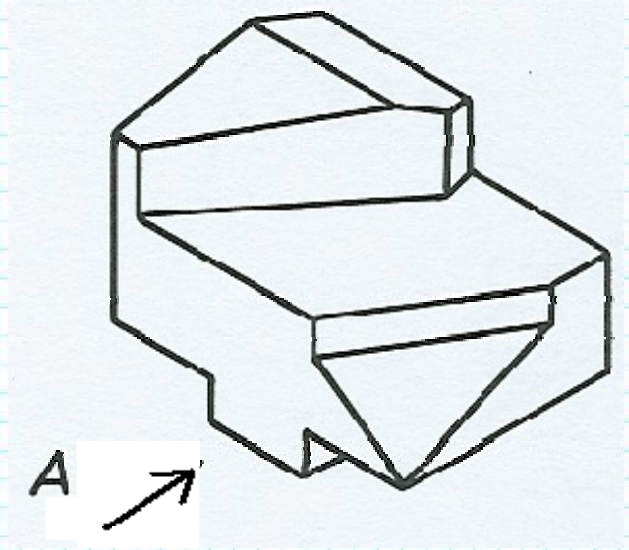

6

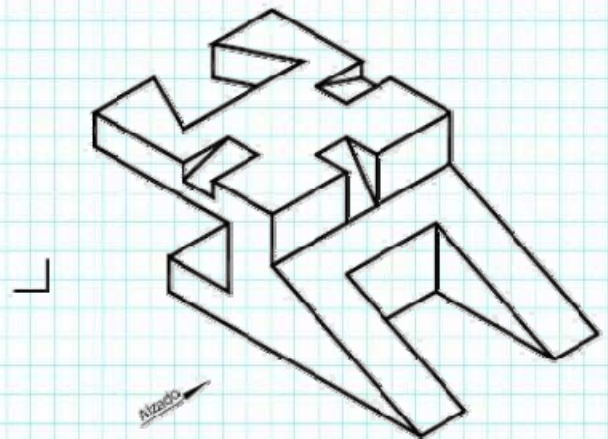

I
N
T
E
R
M
E
D
I
O



7

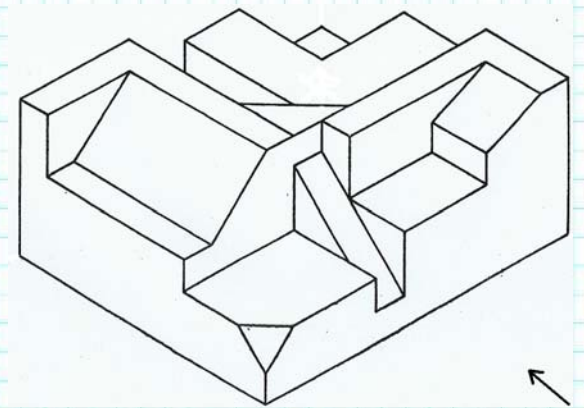

EJERCICIOS. Obtención de Perspectivas.
Tenga en cuenta que en ejercicio 2 falta vista de "Perfil".

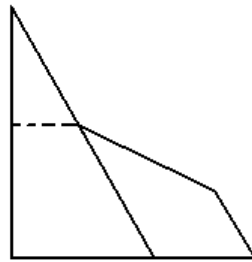
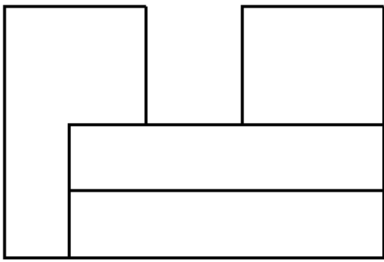

1

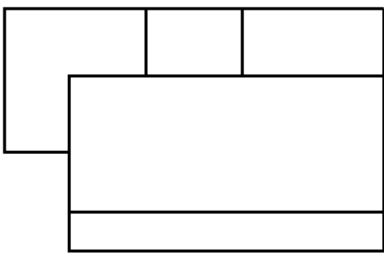

↖
ALZADO

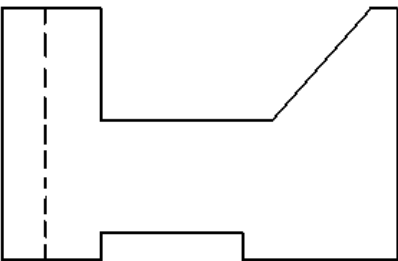

2

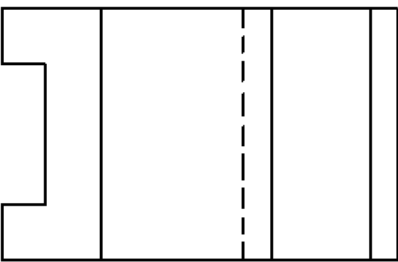

↖
ALZADO

I
N
T
E
R
M
E
D
I
O

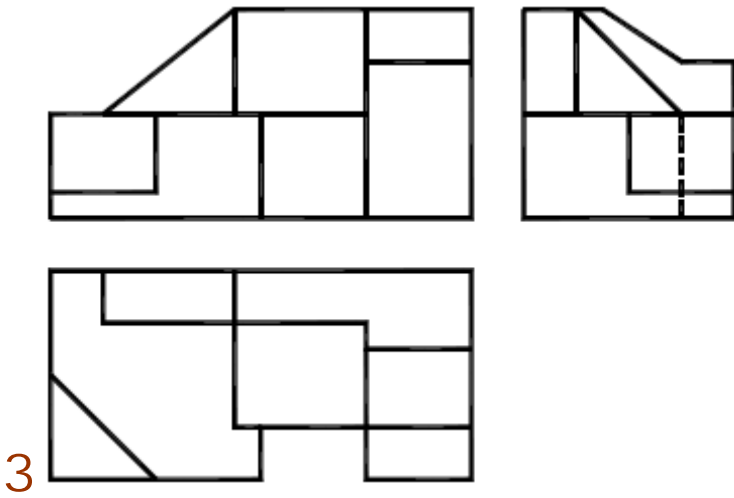

↖
ALZADO

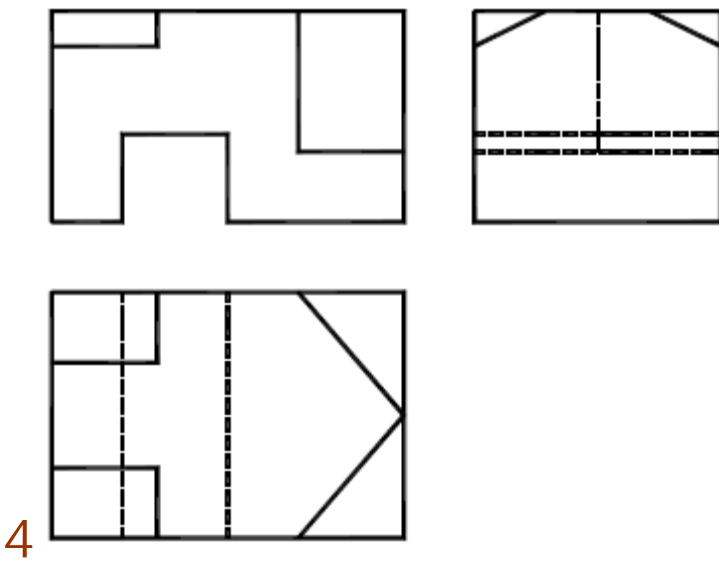

↖
ALZADO

EJERCICIOS. Obtener la vista que falta.

En esta página puedes ver resuelta la forma de obtener el perfil de la pieza propuesta. Realiza los ejercicios propuestos de forma análoga. En los dos primeros ejercicios te puedes ayudar de la perspectiva.

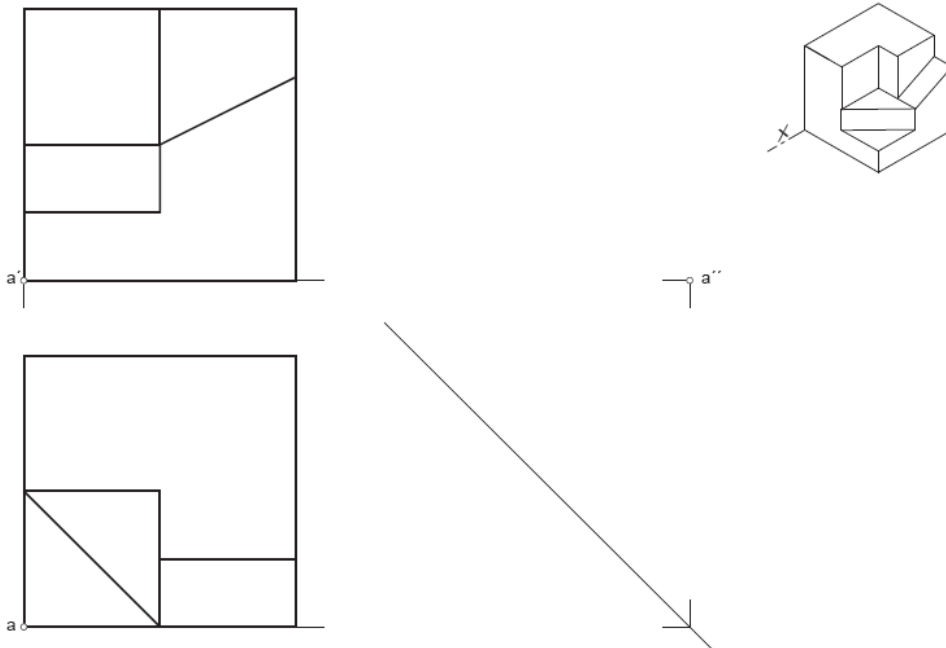

solución

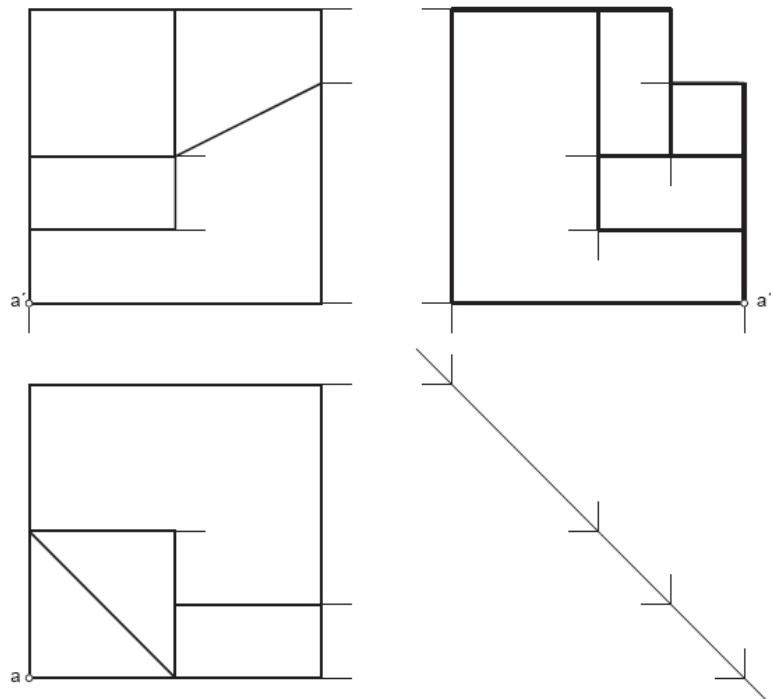

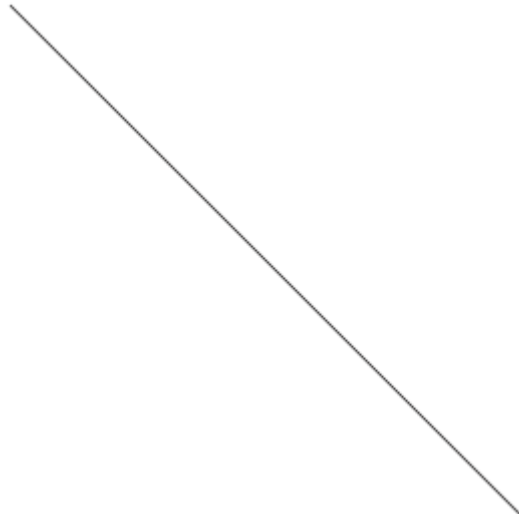
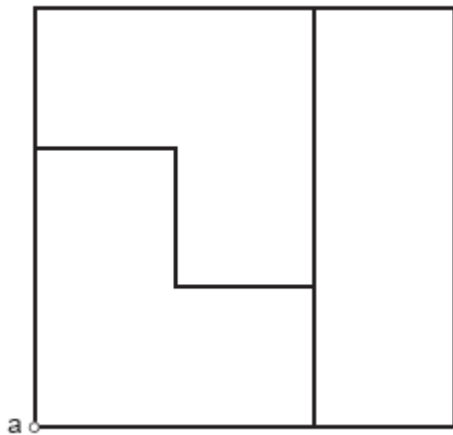
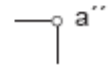
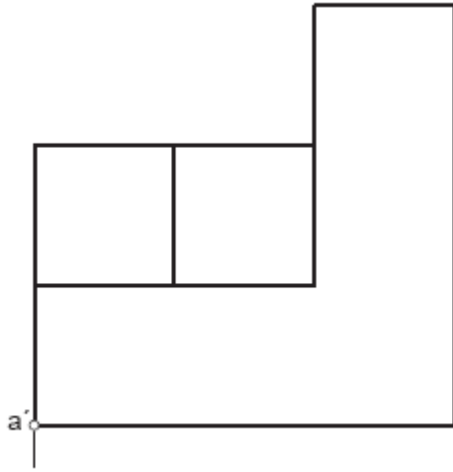

1

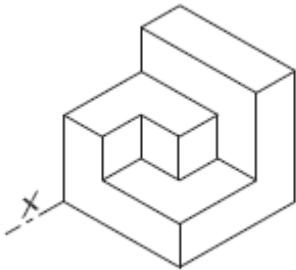

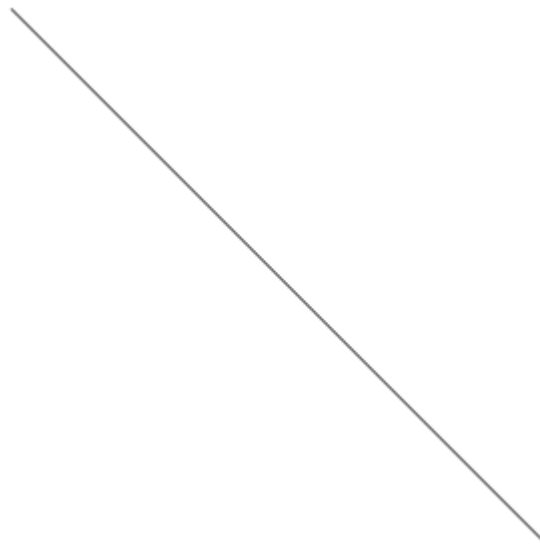
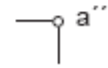
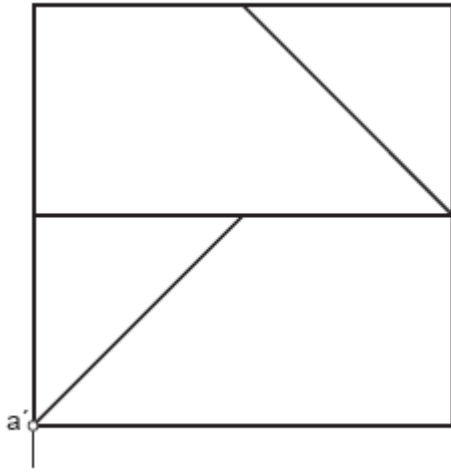

2

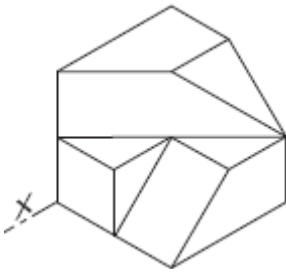

3

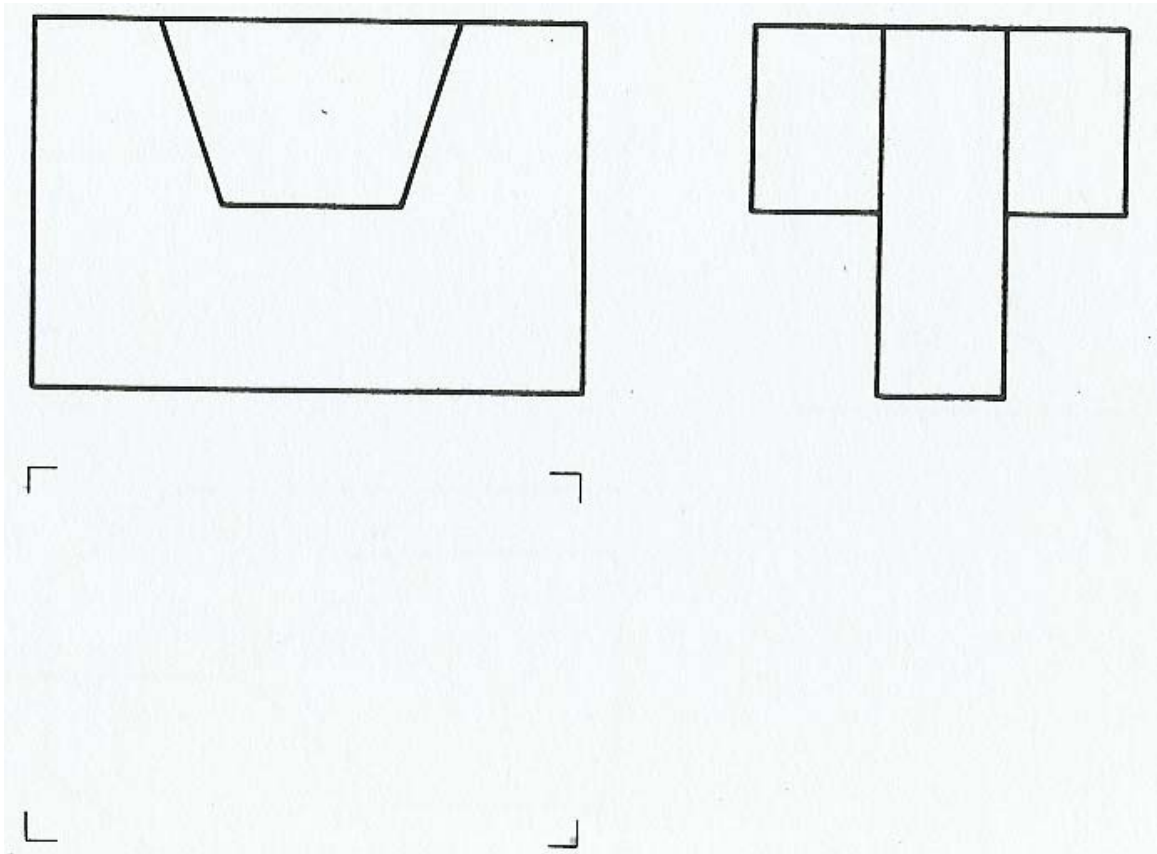

4

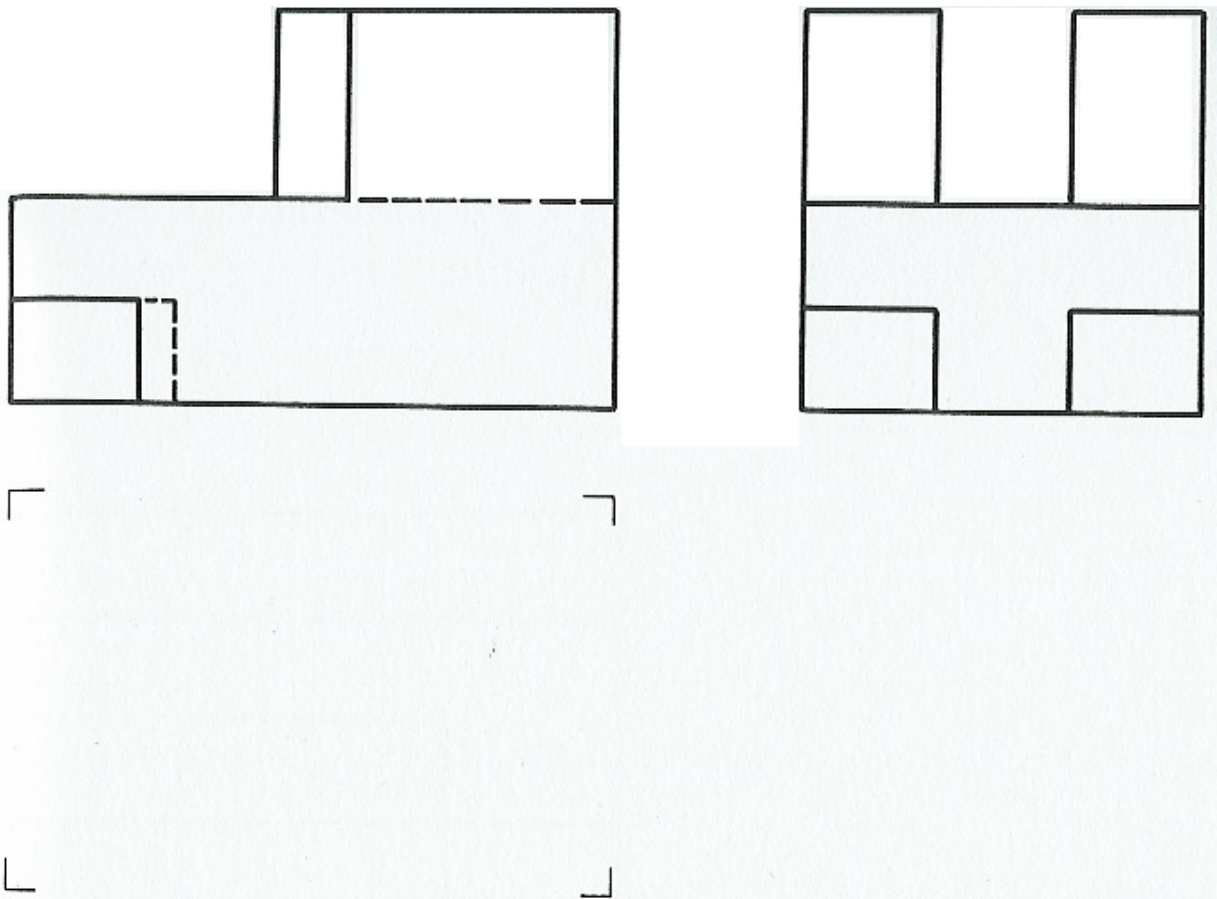

5

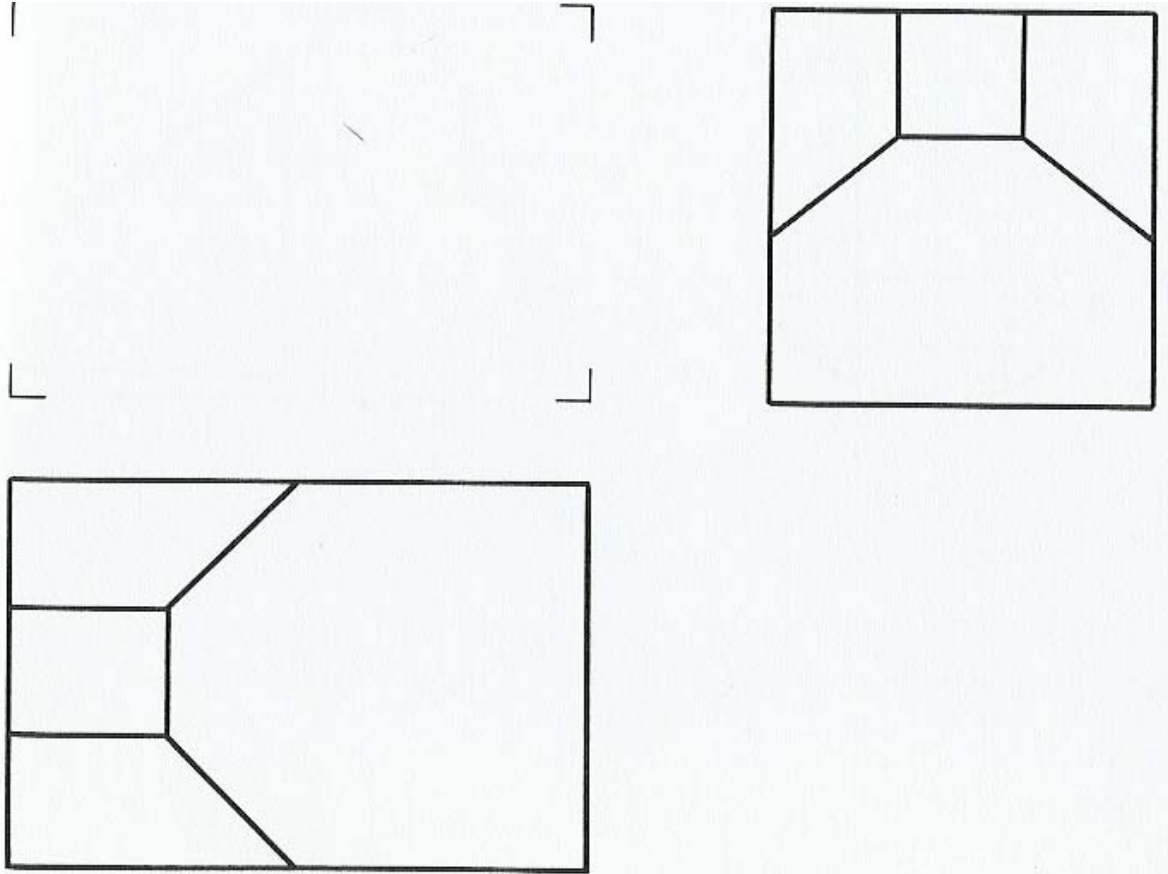

EJERCICIOS. Obtener las vistas mínimas para que la pieza quede perfectamente definida.

1

2

I
N
T
E
R
M
E
D
I
O

EJERCICIOS. Obtener las vistas mínimas para que la pieza quede perfectamente definida. Señala sobre las vistas los vértices marcados en la perspectiva

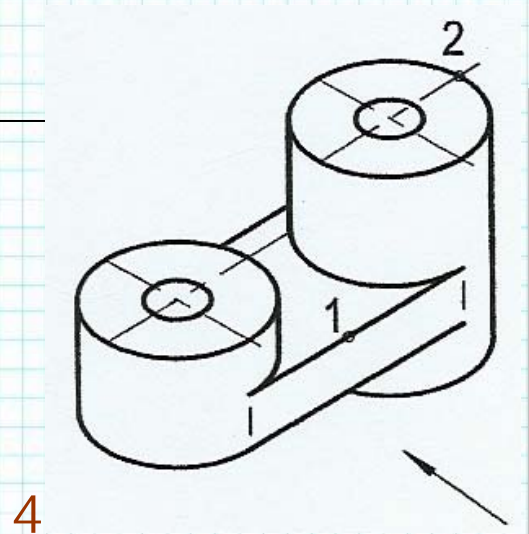
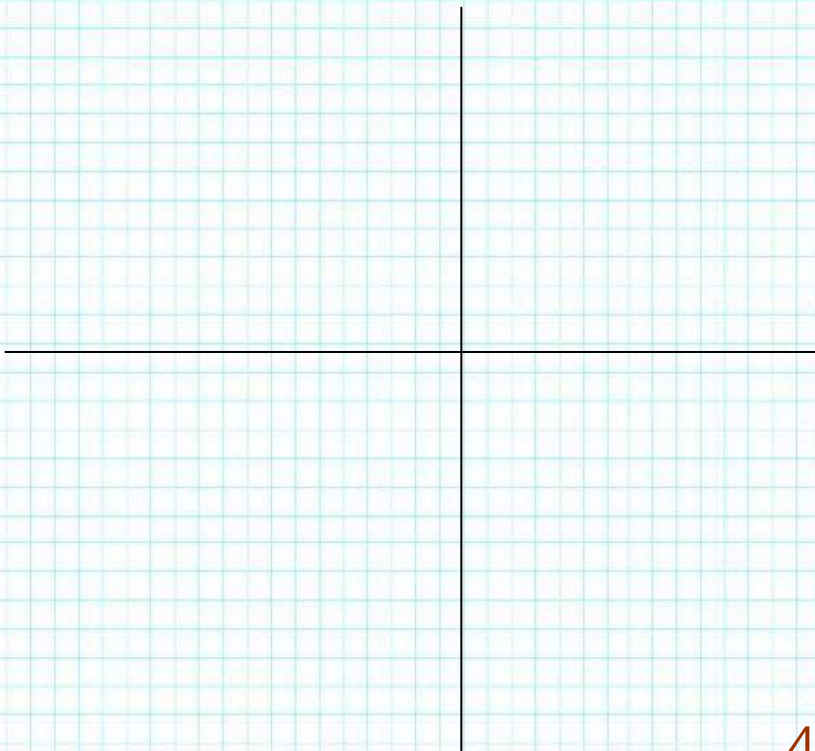
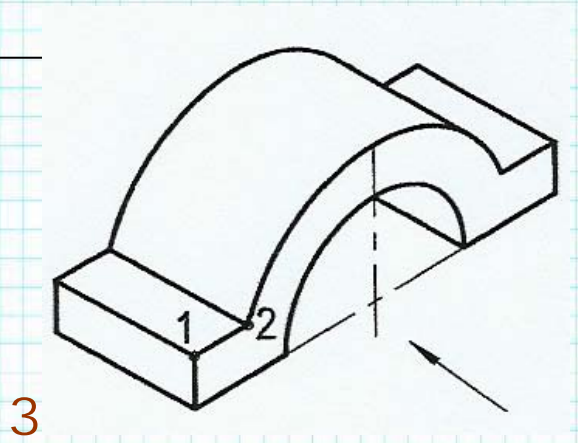
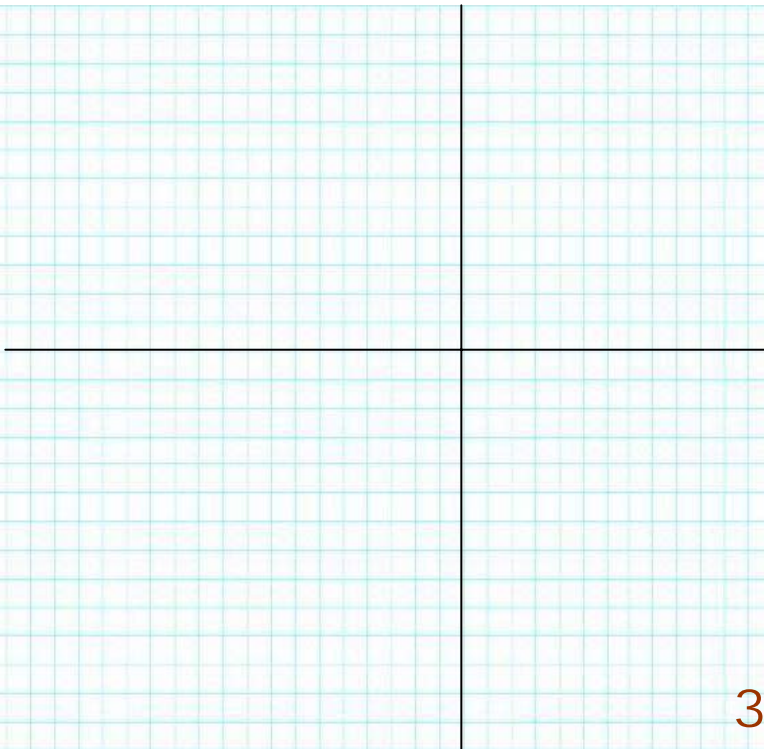

I
N
T
E
R
M
E
D
I
O

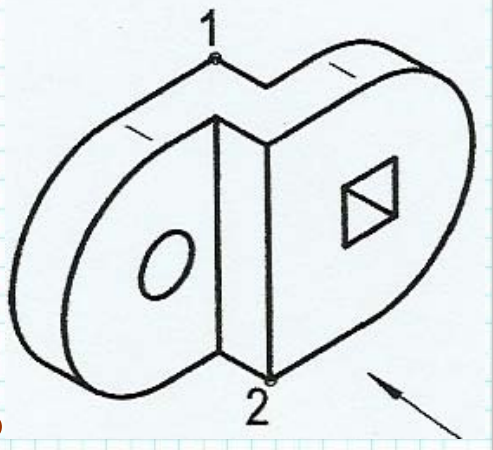
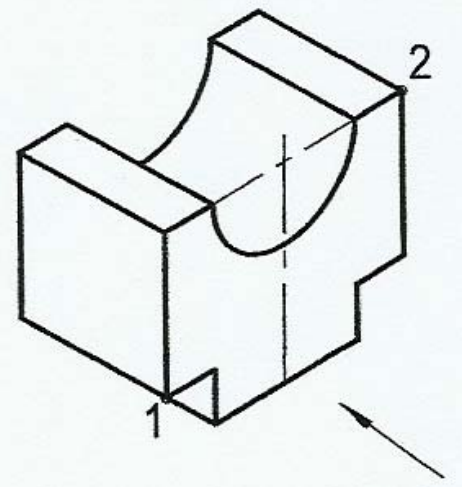

I
N
T
E
R
M
E
D
I
O